

OWNER'S GUIDE & INSTALLATION INSTRUCTIONS

Transom Mount Speed Sensor Kit

Fits Model P66

Patent <http://www.airmar.com/patent.html>

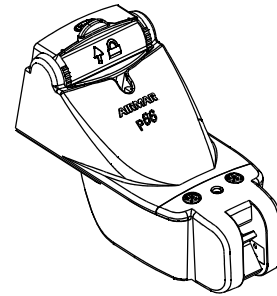

07/18/18
17-282-02 rev. 04

WARNING: Always wear safety glasses, a dust mask, and ear protection when installing.

IMPORTANT: Please read the instructions completely before proceeding with the installation. These instructions supersede any other instructions in your instrument manual if they differ.

Tools & Materials

- Safety glasses
- Dust mask
- Ear Protection
- Phillips screwdriver
- Water-based anti-fouling paint (**mandatory in salt water**)

Servicing

CAUTION: The paddlewheel must be oriented correctly to measure the boat's speed.

1. Remove the two screws that hold the blank onto the transducer housing (Figure 1).
2. Slide the blank upward and discard.
3. Slide the paddlewheel onto the shaft (Figure 2). *Orient the short side of the paddlewheel blade as shown in the side view.*

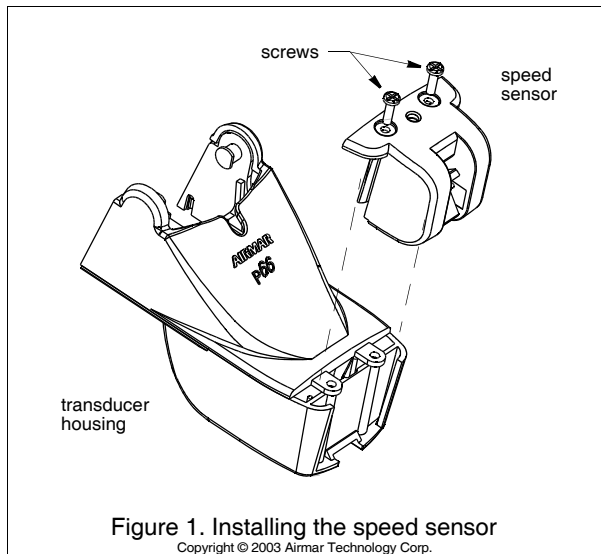

Figure 1. Installing the speed sensor
Copyright © 2003 Airmar Technology Corp.

4. Fit the shaft into the holes marked "B" in the retaining bars.
Note: There is a left retaining bar marked with an L and a right retaining bar marked with an R.
5. Slide the assembly into the speed sensor housing.
NOTE: The interior of the housing is marked with a corresponding L and R.
6. Screw the speed sensor to the transducer housing (Figure 1).

Antifouling Paint

Surfaces exposed to salt water that do not interlock, must be coated with antifouling paint. *Use water-based antifouling paint only.* Never use ketone-based paint, since ketones can attack many types of plastic possibly causing damage to the transducer. Apply paint every 6 months or at the beginning of each boating season.

Cleaning

Aquatic growth can accumulate rapidly on the sensor's surface reducing performance within weeks. Clean with a Scotch-Brite® scour pad and mild household detergent taking care to avoid making scratches on the transducer's face. If the fouling is severe, lightly wet sand with fine grade wet/dry paper.

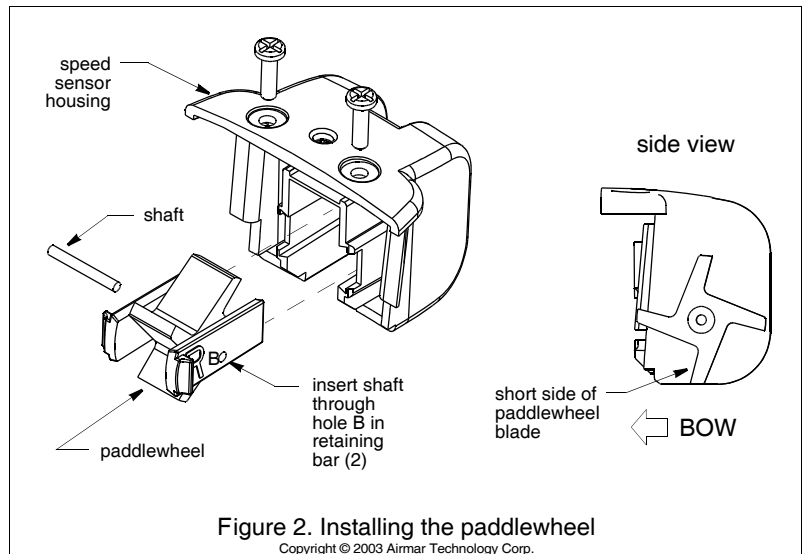

Figure 2. Installing the paddlewheel
Copyright © 2003 Airmar Technology Corp.



35 Meadowbrook Drive, Milford, New Hampshire 03055-4613, USA

• www.airmar.com

Copyright © 2001 - 2018 Airmar Technology Corp. All rights reserved.